

# Multivator

## ROW CROP CULTIVATOR

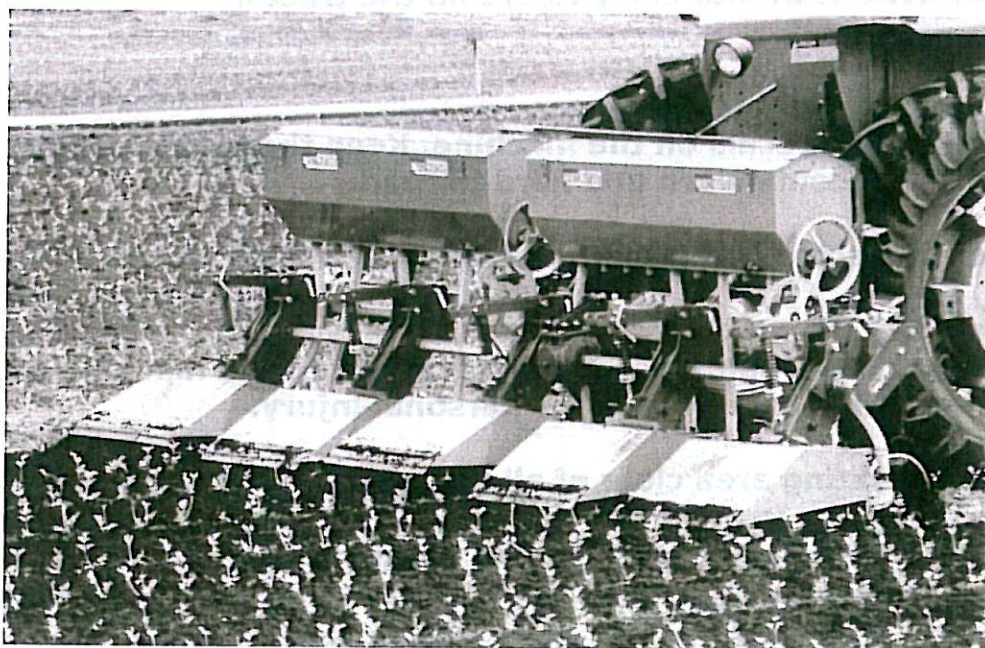

## OPERATOR'S MANUAL & PARTS LIST

**MODELS: FPSR, FPSRXA**



## **SAFETY PRECAUTIONS**

**READ THIS OPERATOR'S MANUAL CAREFULLY!** Read and understand these safety precautions before operating the Multivator. Only responsible properly trained individuals should be allowed to operate the machine. The operator should be familiar with the controls, all safety precautions and all potential hazards.

Never allow children to operate the Multivator. Do not permit anyone to ride on the Multivator. Do not carry riders on the tractor.

### **OPERATION**

- 1. Follow all safety decals on the machine. Keep them clean and replace them if they become worn and hard to read.**
- 2. Never leave tractor or Multivator unit running unattended.**
- 3. Do not modify the machine in any way unless authorized by Ford Distributing, Inc. Unauthorized modifications to the machine could result in machine damage and/or personal injury.**
- 4. Keep the operating area clear of all persons – particularly small children and pets. Inspect the operating area before using the Multivator and remove any obstacles which could damage the machine, or become entangled in the blades.**
- 5. Use only attachments or accessories designed for your Multivator.**
- 6. Do not operate the Multivator without all guards, shields and other safety devices correctly installed.**
- 7. Never use an unshielded PTO shaft, and always attach the shield retainer chain to the tractor or Multivator.**
- 8. Do not allow bystanders behind the Multivator when in operation. Rocks may be thrown to the rear.**
- 9. Do not operate the universal drive joint at an angle greater than 35°, or vibration and damage could result.**
- 10. Do not till across the face of slopes. Use extreme caution when turning on slopes.**



## **SAFETY PRECAUTIONS**

- 11. Operate the Multivator only when you have good visibility. Make sure your feet are properly placed on the footrests and keep a firm grip on the steering wheel.**
- 12. Be careful not to touch tractor or Multivator parts which may be hot from operation. Allow parts to cool first.**
- 13. Whenever leaving the tractor and Multivator unattended, disengage the PTO, shift into neutral, set the parking brake, lower the machine, stop the engine and remove the ignition key.**
- 14. Always disengage power to the Multivator when transporting or when not in use.**

## **MAINTENANCE AND STORAGE**

- 1. Never adjust, clean, repair or grease the Multivator or tractor with the tractor engine running. Stop the engine, disengage the PTO and remove the ignition key whenever you are not at the operating controls.**
- 2. Do not crawl under the Multivator when it is in a raised position. Never rely on tractor hydraulics to hold the machine in a raised position. Always provide support with blocks before adjusting, cleaning, repairing or greasing the machine.**
- 3. Check tightness of bolts, nuts, spring pins and clip pins frequently to ensure a safe working condition.**
- 4. Follow the daily lubrication and periodic maintenance procedures as described in the Operator's Manual.**
- 5. When storing the Multivator, make sure it is securely blocked in a safe, level position.**
- 6. Follow proper maintenance and repair schedules to keep unit in safe working order.**
- 7. Always use proper protective equipment when working on unit.**



## **SPECIFICATIONS**

### **POWER RANGE**

**FPSR/FPSRXA: 50-150 PTO Horsepower**

### **TRACTOR REQUIREMENTS**

**540 RPM standard rotation PTO  
Category I or II three point hitch**

### **TRANSMISSION**

**By shielded PTO shaft assembly to single speed gearbox for use with 540 RPM tractor PTO.**

**Friction disc slip clutch is available for extremely rugged or stony conditions.**

**Input shaft on Multivator gearbox is 1-3/8" 6 spline.**

### **FINAL DRIVE**

**Power to rotor and blades is by heavy duty roller chain in sealed oil bath drive case assembly.**

**FP/FPA/FPSA use 100H (20B) equivalent chain**

### **ROTOR AND BLADES**

**Multivator heads are equipped with four blades per flange. Blades are forged from chrome alloy steel, heat treated and shaped to take minimum power with maximum tillage ability.**



## **SPECIFICATIONS**

### **DEPTH CONTROL**

The frame height is controlled by front mounted gauge wheels. Depth is controlled by adjusting the gauge wheel height via the screw jack assembly.

Spring tension on the tillage heads provides positive down pressure to keep tillage heads at maximum depth while allowing the heads to float over undulations and stones. In hard soil conditions, spring tension may be increased to provide more down pressure. In stony conditions spring tension may be eased to allow for more flotation.

### **GROUND SPEED**

Ground speed is governed by power and soil conditions. Hard ground will require lower travel speeds to maintain smooth operation. Good ground conditions with reasonable moisture will allow travel speeds of 4-5 mph. Light ground conditions, shallow cultivation or a second pass will allow travel speeds of 5-6 mph.

### **OPTIONAL FERTILIZER KIT**

**Dry granular fertilizer capacities:**

40" hopper – approximately 350 lbs.

60" hopper – approximately 500 lbs.

80" hopper – approximately 650 lbs.

Sufficient downspouts are provided to allow for multiple row requirements. Fertilizer drive is by 2 V-belts and 3 pulleys. Drive pulley is mounted to same hexagonal shaft which power tillage heads.

### **ROTOR SPEEDS AT 540 RPM PTO SPEED**

**FPSR/FPSRXA      312 RPM**

### MACHINE DESCRIPTION

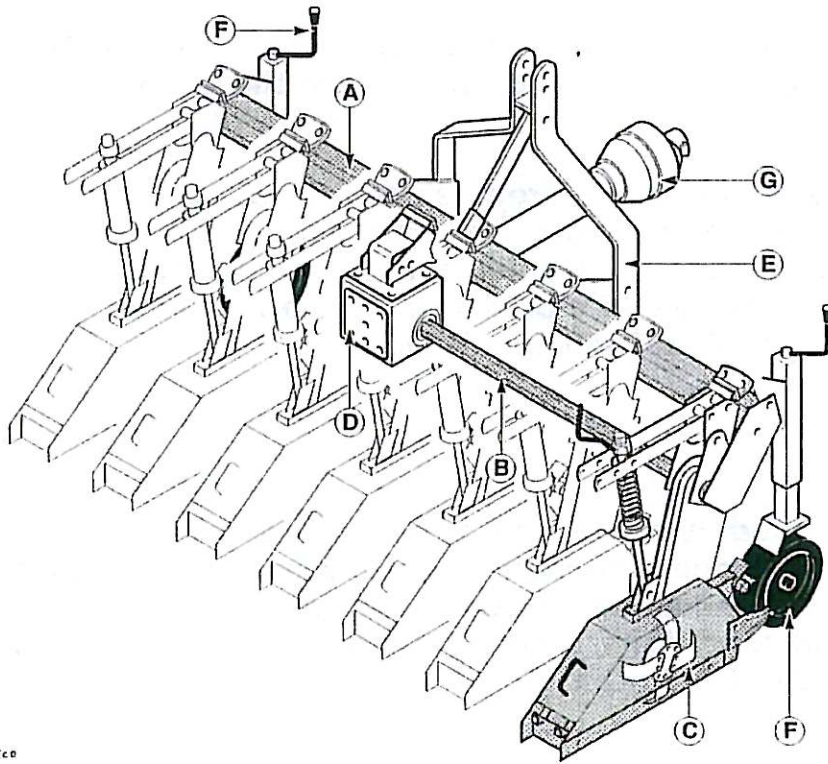

015014 Eco

**A. Toolbar**

**B. Hex Drive Shaft**

**C. Tillage Heads**

**D. Gearbox**

**E. Three Point Hitch**

**F. Gauge Wheels**

**G. PTO Shaft**

### MACHINE DESCRIPTION

#### Steering Guide

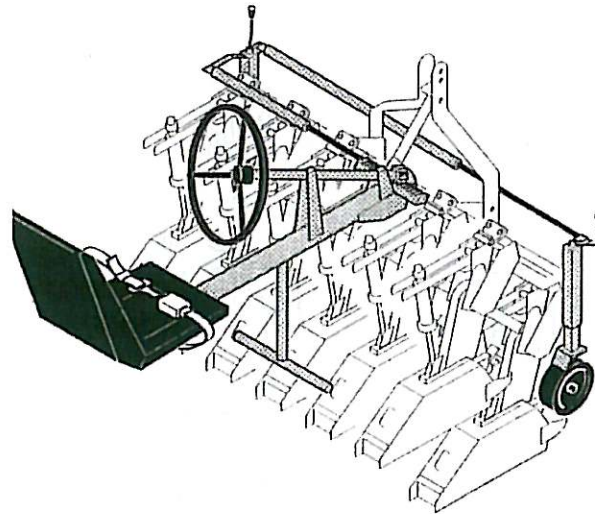

#### Ridger Assembly

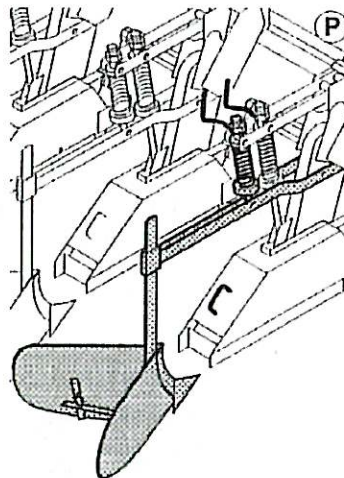

### BLADE CONFIGURATION FPSR/FPSRXA

Head Sizes

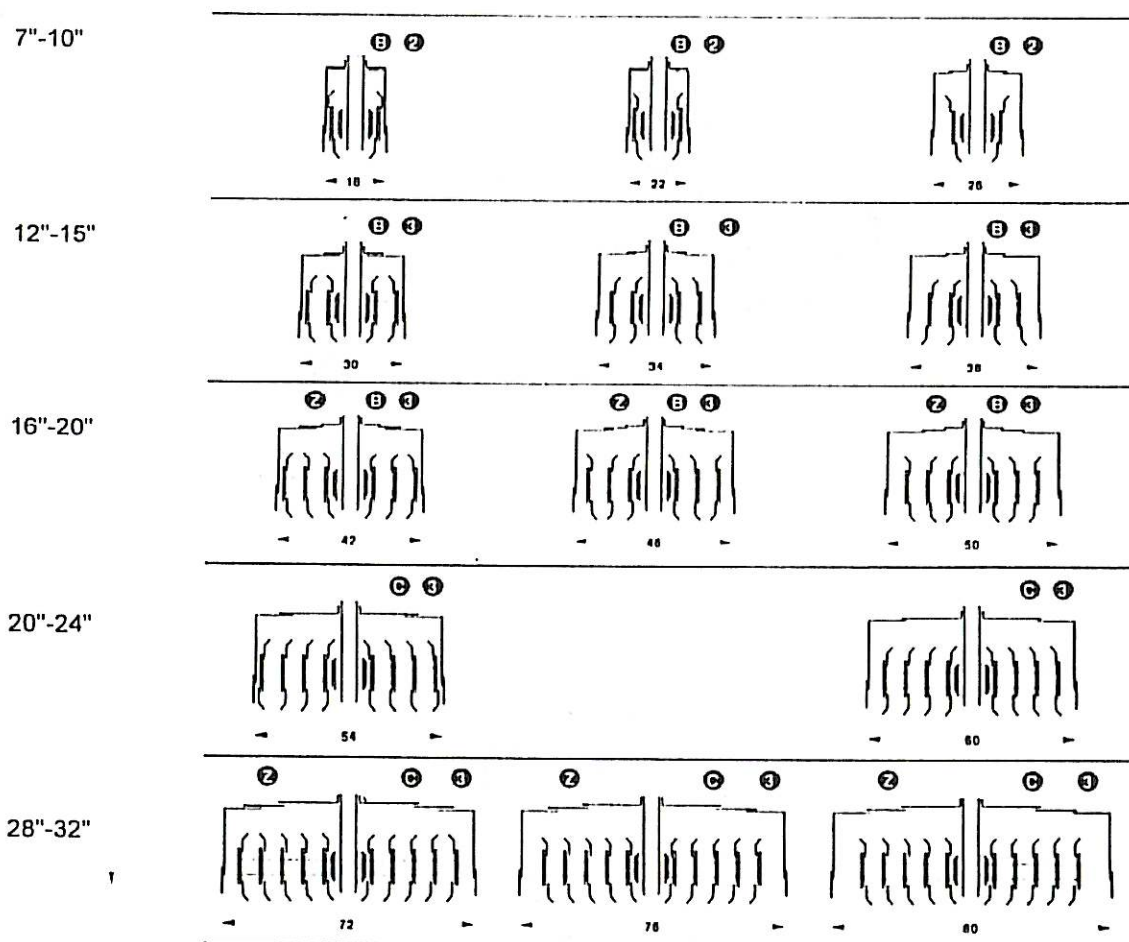

REFERENCE	PART NUMBER	DESCRIPTION
B	420160005	Narrow center shield
C	420160006	Medium center shield
D	420160007	Wide center shield
Z	420252005	Medium side shield R.H.
Z	420254005	Medium side shield L.H.
3	420252006	Wide side shield R.H.
3	420254006	Wide side shield L.H.
Z	320070003	Extension shield



### MOUNTING MACHINE TO TRACTOR

1. Ensure that the tractor PTO is set for 540 rpm.
2. Stabilizers must be used on 3 point hitch arms to limit side sway.
3. A lift stop must be fitted to the hydraulic lift lever to prevent over lifting of the Multivator while in operation.

When lifting the Multivator during normal operation, ground clearance of 6-8" under the blades is completely adequate. Under no circumstances should the Multivator be raised to the point where damage to the universal joints on the PTO shaft occurs.



Never operate the machine with the universal joints at an angle greater than 35°. Excessive wear and damage will result!

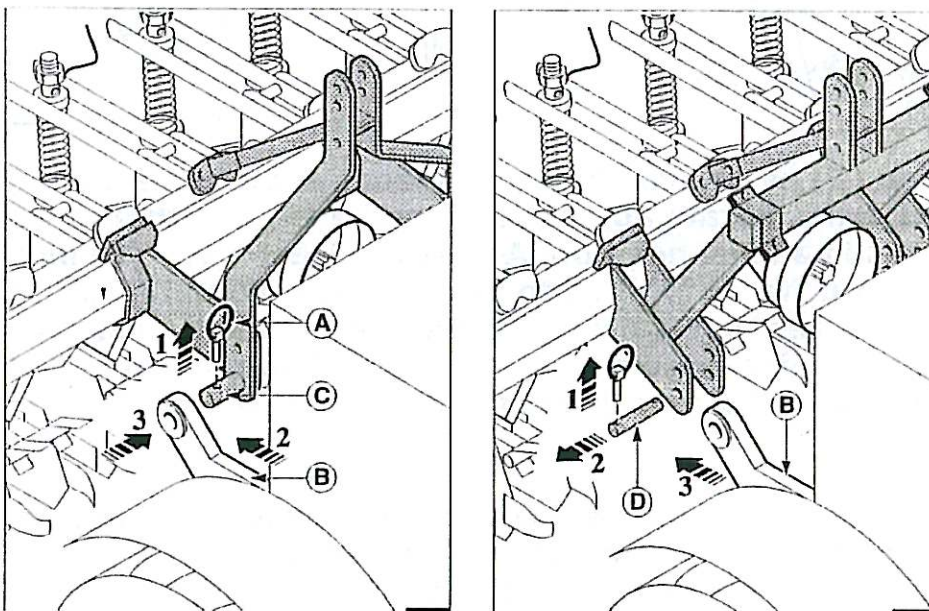

4. Back the tractor up to the hitching points on the Multivator. Stop a few inches away and set the tractor hitch arms to the height of the Multivator hitch pins. Shut off the tractor engine.

# Multivator

## TECHNICAL INFORMATION

5. Remove the split pins (A). Roll Multivator into position and insert the hitch arms (B) into the pins (C). Reinsert split pins (A) to lock pins into position. If machine is equipped with removable hitch pins, pins must be removed before fitting the tractor arms into position.

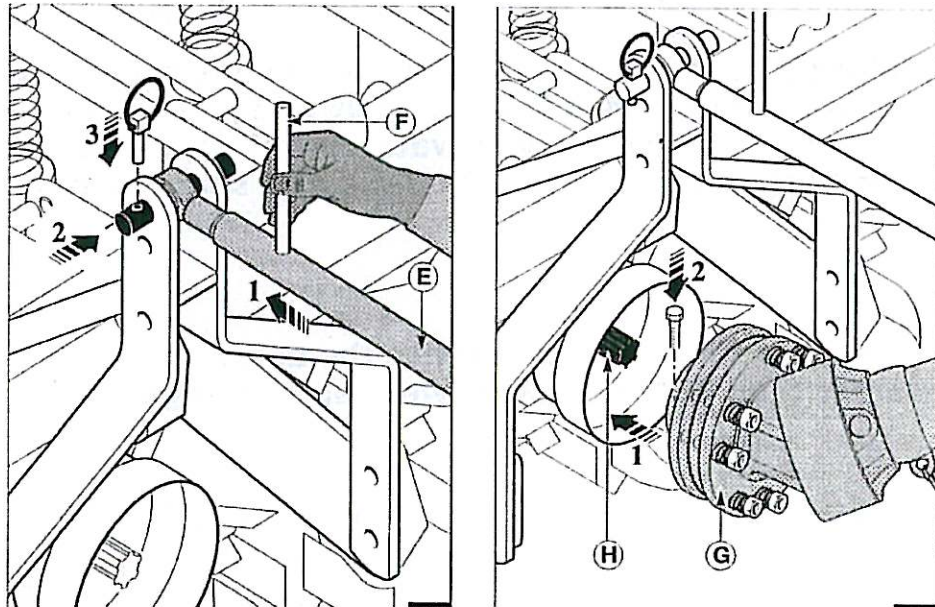

6. Position tie rod (E) as shown above. Connect tie rod to machine from tractor's third point. Rotate adjustment handle (F) in either direction until machine is in a level position. Adjust the tractor top (E) link so that the Multivator frame is tilted to the rear approximately  $5^{\circ}$  from vertical. This ensures that the leading edge of the tiller shield is higher than the trailing edge and will not plow into the ground. Make this adjustment with the machine resting on the ground.
7. Connect the PTO shaft assembly (G) to the Multivator gearbox input shaft (H). Connect the other end of the PTO shaft assembly to the tractor PTO shaft. Ensure that the quick disconnect pins snap into place on both shafts.



At this point you may have determined that the PTO shaft assembly needs to be shortened. If you can connect the PTO shaft to the tractor and Multivator without shortening it, you must ensure that the PTO shaft will not bottom out during operation. This may occur when raising or lowering the Multivator. If the shaft bottoms out during operation damage may occur to the PTO shaft assembly, Multivator gearbox and the tractor PTO.

**Multivator**

## TECHNICAL INFORMATION

Following are 2 techniques for measuring for the correct length of PTO shaft:

- a. With the Multivator attached to the tractor, measure the horizontal distance from the input shaft on the gearbox to the tractor PTO shaft. Place the fully closed PTO shaft assembly on the ground and measure its overall length. If the PTO shaft assembly is shorter than the distance between the tractor PTO shaft and gearbox then you should not have to shorten it. If it is longer, then subtract the shorter measurement from the longer measurement. Add 1" to the difference. The result is the excess length that will need to be removed from each half of the PTO shaft assembly.
- b. With the Multivator attached to the tractor, separate the PTO shaft assembly into two halves and attach one half to the tractor and one half to the Multivator. Hold each half alongside each other and determine the excess length of each half of the PTO shaft assembly.

### PROCEDURE FOR CUTTING THE PTO SHAFT:

- a. Separate the PTO shaft into two halves.
- b. Using the measurement obtained above, shorten the plastic guarding using a hack saw.
- c. Using a chop saw, or a hack saw, shorten the steel profile tube by the same amount.
- d. Cut each half of the PTO shaft.
- e. De-burr the profile tubes.
- f. Grease and reassemble the PTO shaft.

**PRE-WORK INSPECTION**

Before using your Multivator, perform the following checks and services each day. (See Maintenance section for further details.)

1. Check gearbox for sufficient oil. If oil is to be added, use SAE 140 EP gear oil.
2. Grease the PTO shaft sliding sections and universal joints.
3. Grease the gauge wheel axles.
4. Remove any trash or material wrapped around the rotor or the rotor bearing covers.
5. Check for loose blades. Tighten any blade bolts as necessary. Loose blade bolts can lead to broken blades.
6. Check all bolts on machine for tightness.

**SETTING DEPTH**

Cultivation depth is controlled by raising or lowering the gauge wheels on the front of the tool bar. With the Multivator attached to the tractor, and with the blades resting on the ground, raise the gauge wheels to the desired cultivation depth. Typically, this will be between 1" and 4" deep.

**WORKING**

Start the tractor engine and lift the Multivator clear of the ground. Six to eight inches should be sufficient height to lift the machine. Proceed to the work site and position the tractor for the first run.

Engage the tractor PTO, select a low gear, and move ahead slowly lowering the Multivator into the ground. Use at least  $\frac{3}{4}$  throttle when starting and increase to rated engine speed at 540 PTO rpm as the Multivator sets into the soil.

The Flow Rate Control Knob for the tractor hydraulics may need to be set to the "Slow" position to ensure gentle lowering of the machine into the ground. Also make sure that the three point hitch is set in the "Float" position.

After a short working distance, stop the tractor and check your work to see that desired results are being obtained.

### **RUNNING IN**

For the first 10 hours of operation, run the Multivator easily. Do not allow the Multivator to lug the tractor down. Check the temperature of the gearbox and chaincase units to ensure that they are not operating at excessive heat levels. High temperatures can be an indication of a potential problem with a component, low oil levels, or possibly an assembly problem.

### **GROUND SPEED**

Ground speed is governed by power and soil conditions. Hard ground will require lower travel speeds to maintain smooth operation. Good ground conditions with reasonable moisture will allow speeds of 4-5 mph. Light ground conditions, shallow cultivation, or a second pass will allow travel speeds of 5-6 mph.

### **ENGINE RPM**

Try to operate at the rated engine speed to achieve 540 RPM PTO speed. Allowing the tractor to lug down continuously can result in damage to the tractor and the Multivator.

### **SOIL TILTH CONTROL**

Tilth is governed by forward speed and engine RPM. Slower forward speeds will give the finest possible finish. Higher forward speeds will give a cloddier or rougher finish.

**HEADLAND PROCEDURE**

Each time the headland is reached, lift the machine clear of the ground (6" to 8" maximum). With the blades rotating, turn the tractor for the next pass, and slowly lower the machine into the ground.

**DO NOT TURN THE TRACTOR WITH THE MULTIVATOR IN THE GROUND!**

**WORKING LIMITATIONS**

It is very important that the Multivator be used in conditions that will not obviously damage the machine. The Multivator has the ability to handle small stones and other obstacles by "walking over" these obstacles and kicking them out behind the machine. The forward rotating blades, and free floating heads, allow for this action to occur.

Extremely rugged conditions will cause excessive wear and tear on blades, shielding, and working components of the machine, requiring more operator maintenance.

If the blades do not penetrate the soil easily, and you can not obtain more than 1" depth on a first pass with wheels clear of the ground, conditions may be too dry and hard. Continued use of the Multivator in such conditions will cause excessive wear on the drive train and will void any warranty consideration.

If considerable vibration, jumping, and shock loading is apparent, then the conditions are not suitable to work in.

If these conditions are unavoidable, then please adhere to the following guidelines:

- Try to irrigate, or wait until adequate soil moisture is present
- Use another tillage tool, such as a chisel shank or V-ripper, to relieve compaction before using the Multivator
- Relieve spring tension on the tiller heads to allow them to float more easily over obstacles
- Fit a safety clutch to the PTO drive line
- Increase the frequency of machine inspections during operation

- **Be attentive to the machine and any potential problems, particularly loose blade bolts, broken blades, and high fluid temperatures in the gearbox and chaincases**

### **ABRASIVE SOILS**

**Use in very abrasive soils will significantly reduce blade life. These soils are sandy or gravelly in nature.**

**Additional care should be taken to inspect the chaincase skid at regular intervals. The chaincase skid provides important protection to the chaincase, as well as eliminating the center untilled strip. The chaincase skid must be replaced when it is worn out.**

**Optional chaincase wearing shoes are available from the manufacturer. These wearing shoes bolt to the underside of the chaincase and provide an additional wearing surface. They may provide additional protection in very abrasive conditions.**



### **HEAVY TRASH CONDITIONS**

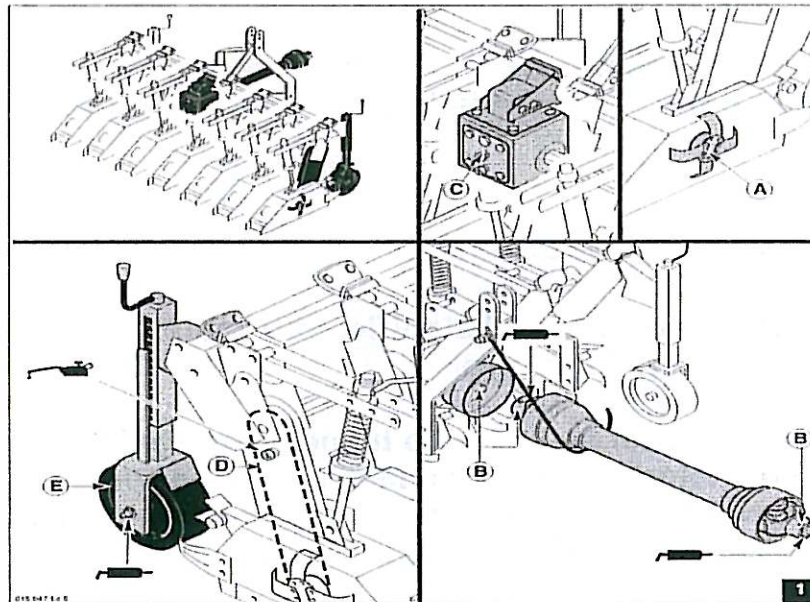

**In very tall weed growth, tough grass tilling, corn residue, stalky or vine type weeds, care should be taken to avoid excessive weed wrap on the blades and rotors. After using the Multivator, clean any residue from the tilling blades, particularly between the inner blade flanges and the chaincase.**

**If trash buildup is occurring on the shields, reposition the shields so they are angled down in the back and up in the front. This is accomplished by repositioning the brackets to which the shields are mounted.**

**If trash buildup is occurring on the center sweep, it may be necessary to remove the "wings" from the center sweep with a torch. The center sweep will then slice through the soil and trash. However, it should be remembered that removing the wings from the center sweep will reduce the effectiveness of the sweep for weed removal.**



Legend:  
 oil  
 grease

Leyenda:  
 aceite  
 grasa

### DAILY

<b>Blades (A)</b>	<b>Check for loose bolts and retighten.</b>
<b>Blade bolts, rotor bolts, flange bolts, shield bolts, clamp plate nuts</b>	<b>Check for loose bolts and retighten.</b>
<b>PTO universal joint bearings (B)</b>	<b>Grease universal joints and sliding sections of PTO shaft with quality grease.</b>
<b>Wheel bearings (E)</b>	<b>Grease with quality grease.</b>

### WEEKLY

<b>Gearbox (C)</b>	<b>Check oil level. Refill if necessary with SAE140EP.</b>
<b>PTO shaft</b>	<b>Clean shaft and check bearings.</b>
<b>Complete Machine</b>	<b>Clean machine for thorough inspection. Check all miscellaneous bolts and nuts to ensure tightness.</b>
<b>Chaincase</b>	<b>Check wearing skids and replace any worn skids as necessary.</b>

**\*\*After initial running period, (approximately 25 hours) drain the gearbox oil and replace. Some discoloration of the oil is normal.**

**\*\*On a monthly basis check the oil level in all chaincases. Remove fill plug to access oil level. Refill all that are necessary with SAE90 gear oil.**



**CHAIN ADJUSTMENT**

On models FL and FLA an automatic chain tensioner is supplied which eliminates the need for manual chain adjustment.

**CHAINCASE LUBRICATION**

Each chaincase is supplied fully lubricated. Over time, lubricant will need to be replaced, and periodically the chaincase may need to be completely flushed and refilled.

Adding lubricant is done through the breather – fill plug located on the side of the chaincase. Chaincases should be filled approximately 1/3 full with good quality SAE90 gear oil. If too much oil is added to the chaincase you will notice oil escaping from the breather plug in a fine mist.

Another method of lubricating the chaincase is to pack the case completely with grease. This can be done when renovating old chaincases with worn components, as the grease helps to seal the chaincase from dirt.

**ROTOR MAINTENANCE**

Remove flanges and draw bolt(s) on a yearly basis, preferably before the initial use for the season. Remove all foreign debris that has accumulated on flanges, blades, rotor, and dust covers. Inspect all flanges, draw bolts, metal dust covers, and oil seals. Replace any and all items with excessive wear. Be sure that oil seals are intact and not leaking chaincase oil.



## TROUBLESHOOTING

PROBLEM	DIAGNOSIS
PTO shaft vibrates or chatters	Check for worn cross and bearing kits. Pay attention to lift height when machine is in use. Lifting machine too high puts the PTO at angles causing premature wear.
Gearbox noise is noticeable or constant.	Check oil level in gearbox. Make sure nothing is obstructing moving components tied to gearbox.
Intermittent clicking noise from rotors, chaincase or gearbox.	Check for loose blades. If noise persists check gearbox for damage to pinion gear or ring gear teeth. Clicking noises inside chaincase can indicate a worn chain skid. Replace as necessary.
Slapping noise from chaincase	Chain is too loose. If chain is worn it should be replaced or shortened if possible.
Hex drive shaft is rotating but blades are not.	This indicates a broken chain link inside the chaincase, broken or rounded off drawbolt.
Burning smell, or signs of excessive heat.	Usually caused by rotors which are not turning freely. Check for trash wrapped around rotor, especially between inner rotor and dust cover.
Blades won't penetrate average soil conditions	Check that blades are installed correctly. Blades or complete flange may have been installed backwards
Machine skips or does not cut all weed residue.	Check for worn blades. If blades are worn down to a sharp point, overlap will be lost and cutting ability will deteriorate. Replace worn blades
Machine vibrates while tilling	Check for bent flanges or a bent draw bolt.

<u>No.</u>	<u>Part Number</u>	<u>Qty.</u>	<u>Description</u>
1	M500130004	2	Screwjack handle
2	M103040034	x	Nut M16
3	M320770004	1	Clamp plate
4	M420610001	2	Upper support FPSR
4	M420610030	2	Upper support FPSRXA
5	M320620006	2	End Plate
6	M103150066	x	Bolt M12x20
7	M320020004	2	Locking ring 50mm
8	M103150034	2	Bolt M10x20
9	M420610011	2	Lower support & axle FP
9	M420610012	2	Lower support & axle FPA/FPXA
10	M101050012	2	Wheel
11	M320210007	2	Spacer
12	M104010002	4	Bearing 6205EZ
13	M320670005	2	Washer
14	M103040072	2	Locknut M16
15	M101040002	2	Hitch pin Cat 1 - threaded
15	M101040004	2	Hitch pin Cat 2 - threaded
16	M420610006	2	Lower hitch bracket
17	M103150135	2	Bolt M16x140
18	M320080031	1	Hex bar 50mm-66"
18	M320080032	1	Hex bar 50mm-90"
18	M320080034	1	Hex bar 50mm-130"
18	M320080034	1	Hex bar 50mm-180"
19	M103090002	2	Grease zerkl
20	M109010004	2	Washer
21	M109020004	2	Felt seal
22	M420680005	1	Link arm
23	M320100008	2	Top mast arm
24	M103150109	1	Bolt M14x100
25	M103150098	1	Bolt M14x35
26	M101020002	1	Split pin

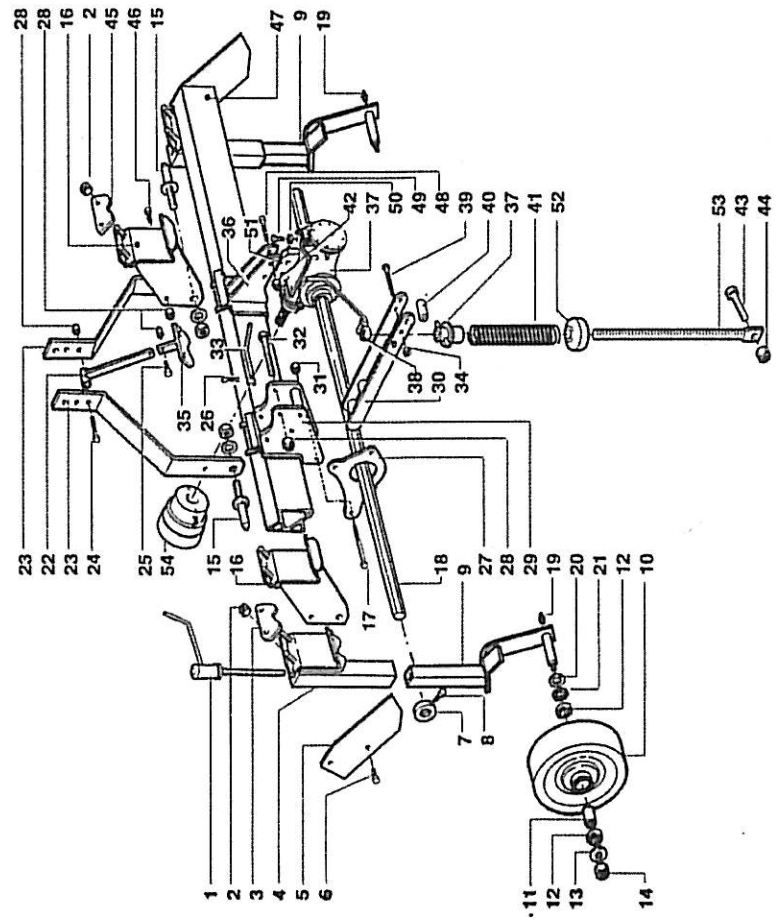

No.	Part Number	Qty.	Description
27	M320570022	2	Chaincase support plate
28	M103040070	1	Locknut M14
29	M420040002	1	Head Clamp
30	M420090002	1	Head support arm
31	M103040034	2	Nut M16
32	M103150112	1	Bolt M14x110
33	M320410002	1	Handle pin
34	M103040014	1	Nut M10
35	M420600002	1	T-clamp plate FPSR
35	M420600007	1	T-clamp plate FPSRXX
36	M410610009	1	Upper gearbox mounting plate
37	M420490003	1	Spring guide
38	M520130003	1	Handle with nut
39	M103150055	1	Bolt M10x90
40	M320210006	1	Spacer
41	M320470004	1	Coil spring
42	M103040068	2	Locknut M12
43	M103150044	1	Bolt M10x30
44	M103040066	1	Locknut M10
45	M320770005	2	Clamp plate
46	M103150101	2	Bolt M14x45
47	M420650009	1	Toolbar - 66"
47	M420650011	1	Toolbar - 90"
47	M420650015	1	Toolbar - 132"
47	M420650017	1	Toolbar - 180"
48	M103150081	2	Bolt M12x60
49	M103150120	4	Bolt M10x20
50	M103100040	4	Washer M10
51	M420610010	1	Lower gearbox mounting plate
52	M420120003	1	Collar
53	M320820006	1	Threaded rod FPSR
53	M320820008	1	Threaded rod FPSRXX
54	M101010002	1	PTO guard

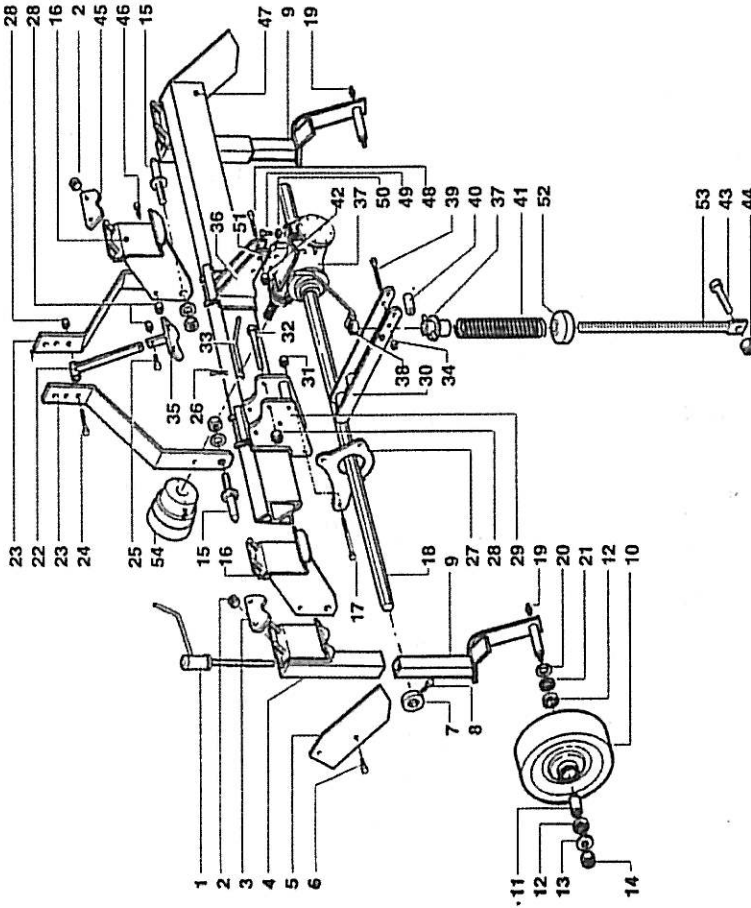

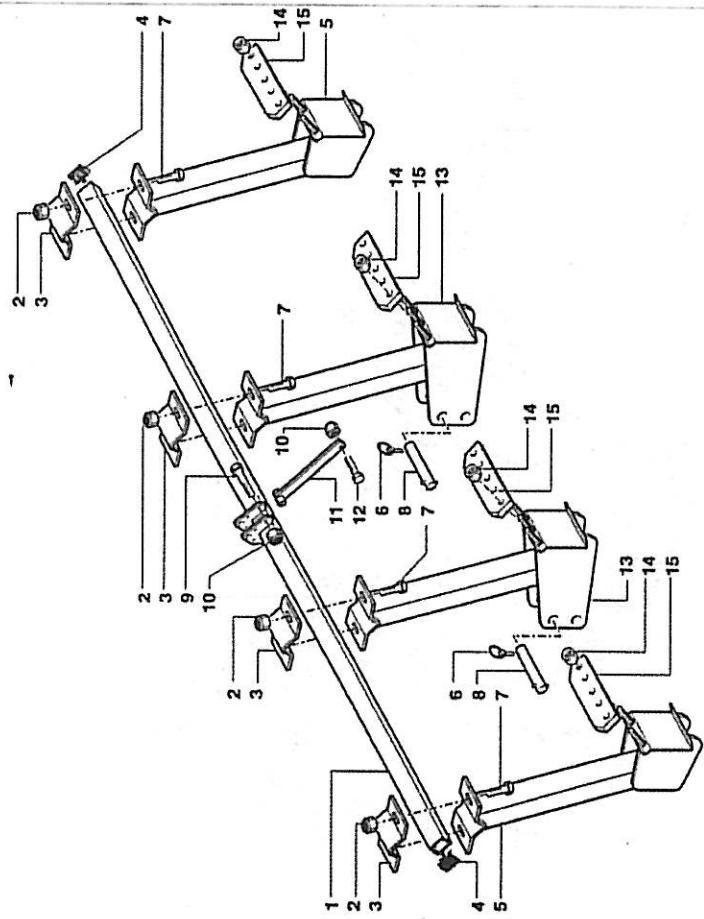

<u>No.</u>	<u>Part Number</u>	<u>Qty.</u>	<u>Description</u>
1	M420610061	1	Top tube
2	M103040072	8	Locknut M16
3	M350770012	4	Clamp plate
4	M103120007	2	Plastic plug
5	M420610059	2	Side support
6	M101070002	2	Clip pin
7	M103150128	8	Bolt M16x55
8	M320560016	2	Hitch pin Cat 2
9	M103150109	1	Bolt M14x100
10	M103040070	2	Locknut M14
11	M420680015	1	Top link bracket
12	M103150098	1	Bolt M14x35
13	M420610060	2	Center support
14	M103040034	10	Nut M16
15	M330770006	4	Clamp plate

<u>No.</u>	<u>Part Number</u>	<u>Qty.</u>	<u>Description</u>
1	M420554008	1	Chaincase half L.H. - FPSR
1	M420554010	1	Chaincase half L.H. - FPSRXX
2	M109040022	4	Oilseal 95x70x13
3	M103140034	1	Bolt M8x70
4	M103140026	x	Bolt M8x30
5	M420610008	1	Front shield support FPSR
5	M420610034	1	Front shield support FPSRXX
6	M103100006	x	Washer M8
7	M103040064	x	Locknut M8
8	M320550004	2	Dust cover
8	M420400002	2	Dust cover FPSRXX
9	M420590003	1	Center sweep
10	M320330003	1	Gasket FPSR
10	M320330005	1	Gasket FPSRXX
11	M104010018	4	Bearing 6014
12	M320210031	4	Spacer
13	M320600007	1	Top sprocket 50mm
13	M320600006	1	Bottom sprocket 41mm
13	M320600008	1	Bottom sprocket - FPSRXX
14	M320090009	1	Bushing
15	M420660011	1	Chainskid FPSR
15	M420660005	1	Chainskid FPSRXX
16	M103040014	1	Nut M10
17	M103150200	1	Bolt M10x70
18	M320620050	2	Chaincase protector (optional)
19	M320580002	2	Plate FPSR
19	M320580088	2	Plate FPSRXX

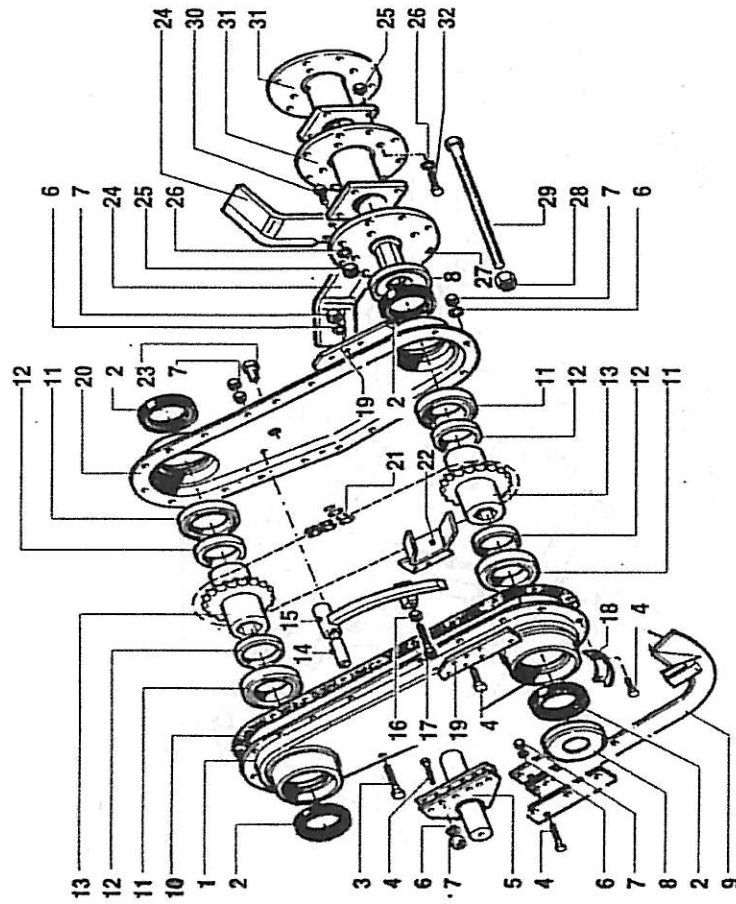

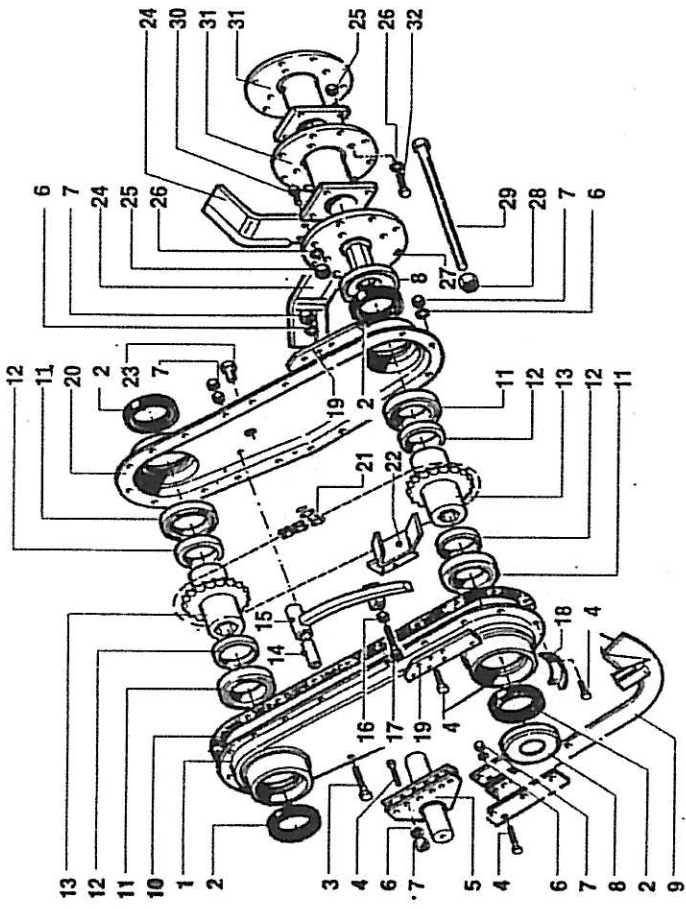

<u>No.</u>	<u>Part Number</u>	<u>Qty.</u>	<u>Description</u>
20	M420552008	1	Chaincase half R.H. FPSR
20	M420552010	1	Chaincase half R.H. FPSRXA
21	M112020034	1	Chain 1-1/4" x 42p FPSR
21	M112020030	1	Chain 1-1/4" x 60p FPSRXA
22	M420030002	1	Rear shield support
23	M320800001	1	Fill plug/breather
24	M111434-L	x	L.H. blade
24	M111434-R	x	R.H. blade
25	M103040024	x	Nut M12x1.25
26	M103100026	x	Lock washer M12
27	M420370011	x	Drive flange
28	M103040078	1	Locknut M20x1.5
29	M420680006	1	Drawbolt
30	M200058	x	Blade bolt assembly
31	M420220004	1	Outer flange
32	M200056	x	Flange bolt assembly

Not Illustrated  
M103040052

x Jam nut M20x1.5 for draw bolt

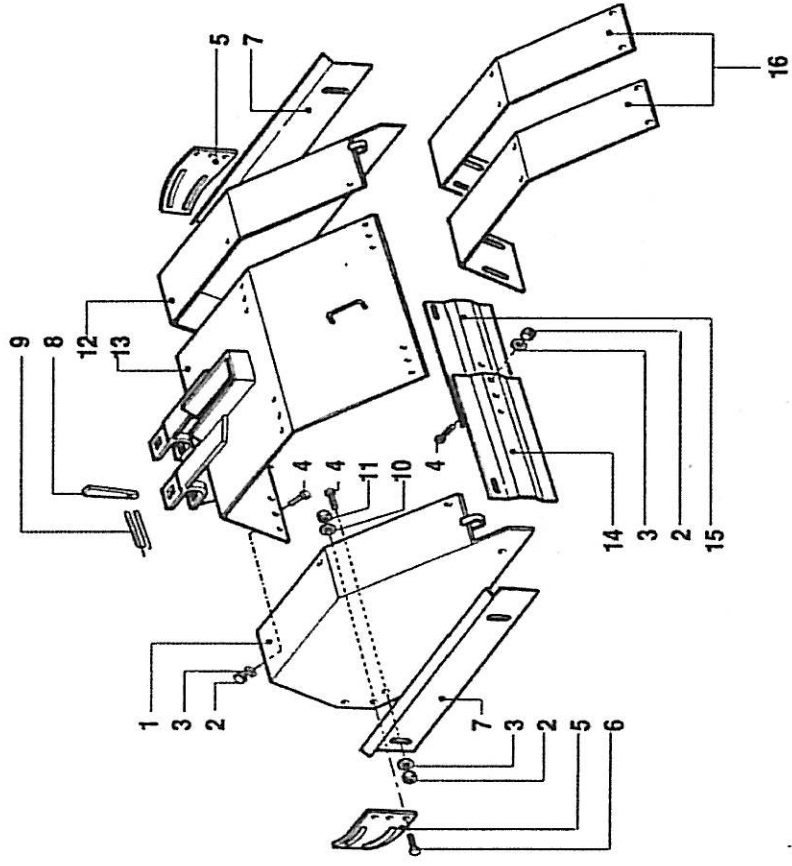

<u>No.</u>	<u>Part Number</u>	<u>Qty.</u>	<u>Description</u>
1	M420254005	1	Side shield medium - L.H.
1	M420254006	1	Side-shield wide - L.H.
2	M103040014	11	Nut M10
3	M103100008	11	Washer M10
4	M103150034	11	Bolt M10x20
5	M300620001	2	Plant guard
6	M103150005	4	Bolt M8x16
7	M320620016	2	Side shield protector
8	M300740001	2	Wedge pin
9	M300470018	2	Spring wire clip
10	M103100006	4	Washer M8
11	M103040008	4	Nut M8
12	M420252005	1	Side shield medium - R.H.
12	M420252006	1	Side shield wide - R.H.
13	M420160005	1	Center shield narrow
13	M420160006	1	Center shield medium
13	M420160007	1	Center shield wide
14	M320624036	1	Trailing board narrow - L.H.
14	M320624038	1	Trailing board medium - L.H.
14	M320624040	1	Trailing board wide - L.H.
15	M320622036	1	Trailing board narrow - R.H.
15	M320622038	1	Trailing board medium - R.H.
15	M320622040	1	Trailing board wide - R.H.
16	M320070003	1	Extension shield



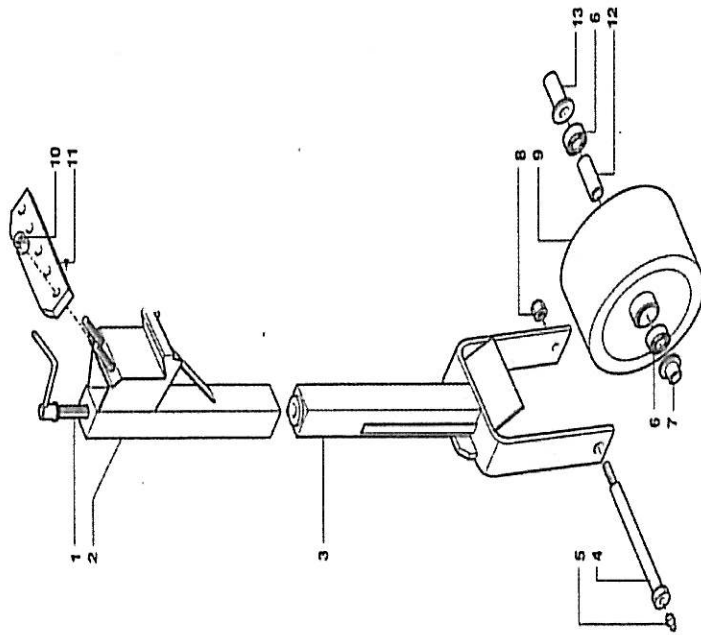

<u>No.</u>	<u>Part Number</u>	<u>Qty.</u>	<u>Description</u>
1	M500130004	1	Screw with handle
2	M420610087	1	Upper support
3	M420610089	1	Lower support
4	M320560030	1	Axle
5	M103090002	1	Grease zerk
6	M104010002	2	Bearing 6205Z
7	M420220010	1	Spacer
8	M103040072	1	Locknut M16
9	M420520002	1	Wheel HD
10	M103040034	2	Nut M16
11	M330770006	1	Clamp plate
12	M320210007	1	Spacer
13	M420220009	1	Spacer

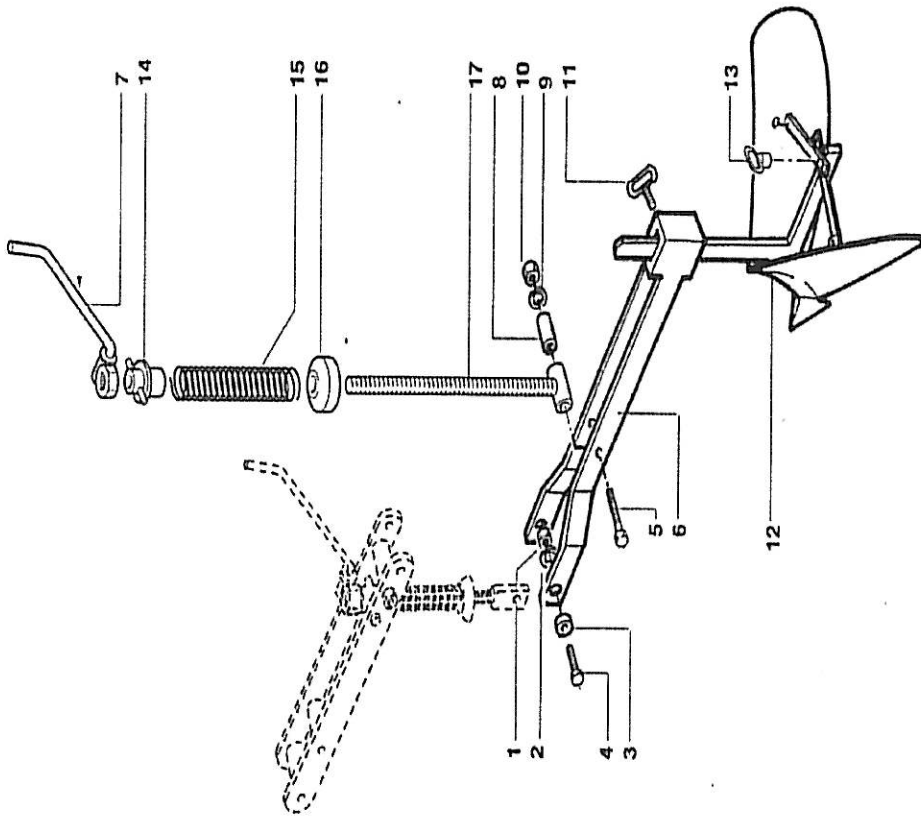

<u>No.</u>	<u>Part Number</u>	<u>Qty.</u>	<u>Description</u>
1	M103040022	2	Nut M12
2	M103100010	2	Washer M12
3	M330090002	2	Bushing
4	M103150072	2	Bolt M12x35
5	M103150090	2	Bolt M12x90
6	M440090006	1	Bracket arm - FPSR
6	M440090008	1	Bracket arm - FPSRXX
7	M520130003	1	Handle with nut
8	M320210012	1	Spacer
9	M103100010	1	Washer M10
10	M103040022	1	Nut M12
11	M440270001	1	Special bolt
12	M500230001	1	Ridger
13	M440270002	1	Washer
14	M420490003	1	Spring guide
15	M320470004	1	Spring
16	M420120003	1	Collar
17	M440680003	1	Threaded rod - FPSR
17	M440680004	1	Threaded rod - FPSRXX
<b><u>Not Illustrated</u></b>			
	M540010006	1	Bracket set FPSR
	M540010008	1	Bracket set FPSRXX
	M540230008	1	Ridger assembly complete FPSR
	M540230010	1	Ridger assembly complete FPSRXX

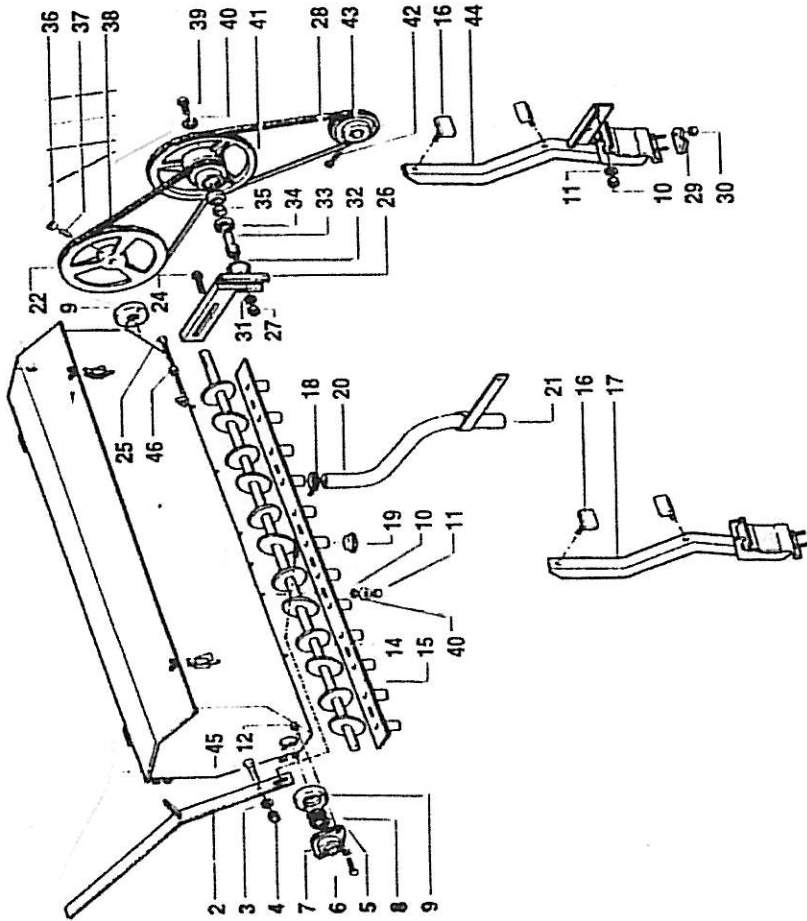

<u>No.</u>	<u>Part Number</u>	<u>Qty.</u>	<u>Description</u>
1	M440140001	1	Hopper 40"
1	M440140002	1	Hopper 60"
1	M440140003	1	Hopper 80"
2	M440300001	1	Shut off lever
3	M103100014	1	Washer M16
4	M103040072	1	Locknut M16
5	M103100006	4	Washer M8
6	M103150017	4	Bolt M8x35
7	M104040002	2	Flange bearing
8	M109020004	2	Felt seal
9	M330250012	2	Bearing support
10	M330090045	6	Bushing
11	M103040068	6	Locknut M12
12	M103040008	4	Nut M8
14	M440310001	1	Agitator 40"
14	M440310002	1	Agitator 60"
14	M440310003	1	Agitator 80"
15	M440070001	1	Slide regulator 40"
15	M440070002	1	Slide regulator 60"
15	M440070003	1	Slide regulator 80"
16	M440640001	4	Mounting bolt
17	M440610028	1	Hopper support arm
18	M101090002	x	Hose clamp
19	M103120006	x	Plug
20	M114010008	x	Hose (order by foot)
21	M330580006	x	Hose guide
22	M330630001	1	Hopper pulley
24	M103150072	2	Bolt M12x35
25	M103150200	1	Bolt M10x70
26	M440610004	1	Idler pulley support
27	M103040034	1	Nut M16
28	M112030006	1	V-belt A52
29	M320770004	2	Clamp plate
30	M103040034	4	Nut M16

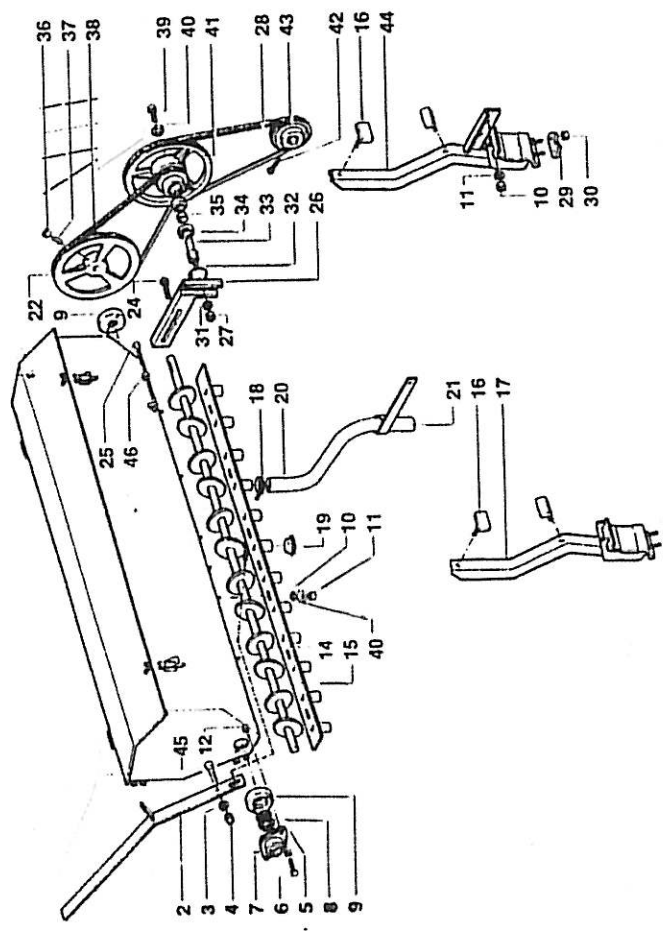

No.	Part Number	Qty.	Description
31	M103100014	1	Washer M16
32	M103010002	1	Snap ring
33	M330560001	1	Idler pulley axle
34	M104010002	2	Bearing 6205Z
35	M330210001	1	Spacer
36	M103040014	1	Nut M10
37	M103070002	1	Socket screw M10x35
38	M112030002	1	V-belt A45
39	M103150034	1	Bolt M10x20
40	M330670001	7	Washer
41	M330630002	1	Idler pulley
42	M103070002	1	Socket screw M10x35
43	M320630005	1	Drive pulley 41mm
44	M440610029	1	Hopper support drive end
45	M103150125	1	Bolt M16x45
46	M103040014	1	Nut M10

No.	Part Number	Qty.	Description
8	M320670005	2	Washer
9	M103040072	2	Nut M16
10	M440410001	2	Pin
11	M103040014	2	Nut M10
12	M103100008	4	Washer M10
13	M101020002	2	Split pin
14	M103040034	6	Nut M16
15	M103090004	2	Grease zerk
16	M440610050	2	Toolbar clamp
17	M330570047	2	Wheel scraper plate
18	M103040064	4	Nut M8
19	M103090002	2	Grease zerk
20	M103150034	6	Bolt M10x20
21	M440050006	1	Steering rod
22	M440490008	3	Guide spring
23	M330090013	2	Bushing
24	M440180001	1	Rack for pinion
25	M103150047	2	Bolt M10x35
26	M440570006	1	Slide
27	M320770004	3	Bracket
28	M109010004	2	Ring
29	M109020004	2	Felt
30	M103040066	3	Nut M10
31	M330040045	1	Rod connection
32	M103140013	2	Bolt M6x50
33	M330600001	1	Pinion
34	M103040062	2	Nut M6
35	M103040008	2	Nut M8
36	M440650060	1	Frame
37	M330090034	1	Bushing
38	M430010001	1	Steering shaft
39	M101080002	1	Steering wheel
40	M103150112	1	Bolt M14x110
41	M101060004	1	Seat
42	M103040070	1	Nut M14
43	M103040072	1	Nut M16

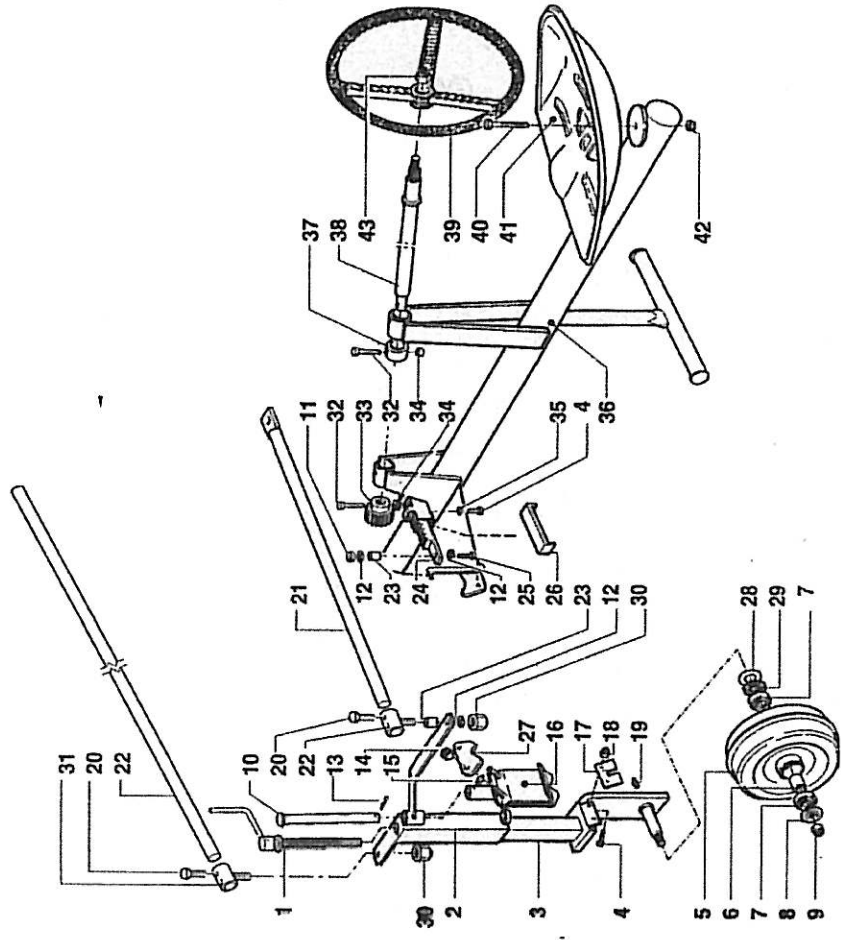

No.	Part Number	Qty.	Description
1	M500130004	2	Handle with screw adjustment
2	M440610049	2	Upper support tube
3	M440610051	2	Lower support tube
4	M103150011	4	Bolt M8x25
5	M101050004	2	Wheel
6	M320210007	2	Spacer
7	M104010002	4	Bearing 6205Z

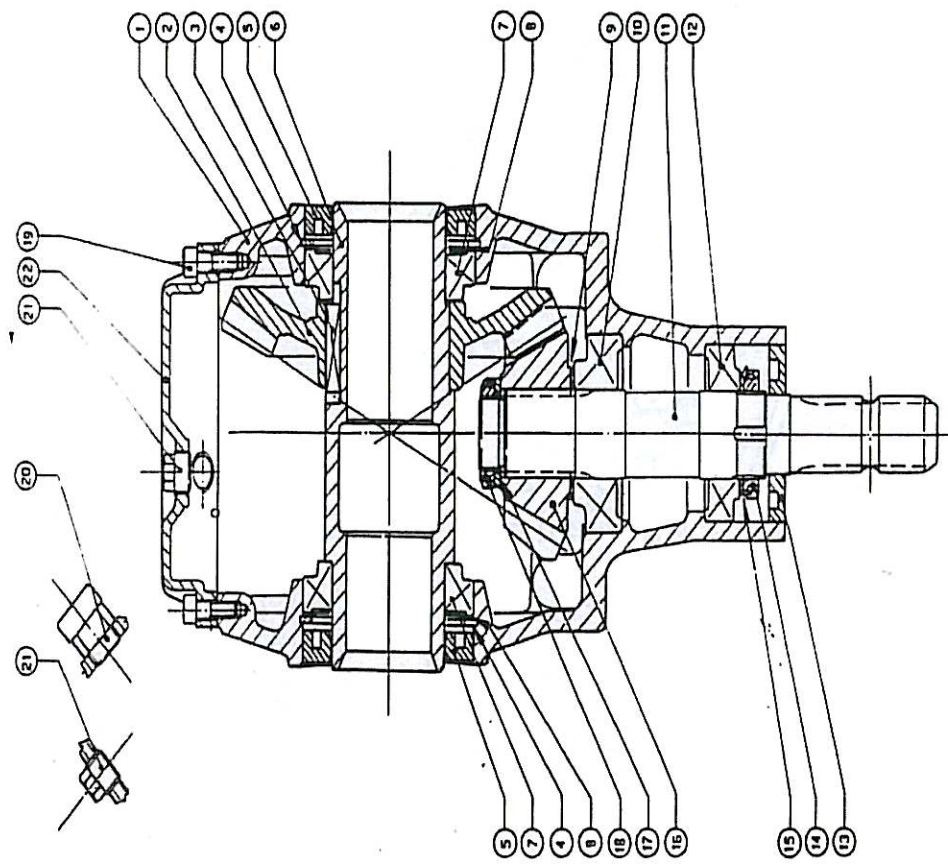

No.	Part Number	Description	Qty.
1	112050050	Gearbox assembly	1
2	02620301	Gearbox housing	1
3	02626003	Crownwheel 29T	1
4	84100978	Key 14x9x40	1
5	85200123	Circlip	2
6	87300948	Oilseal 65x100x12	2
7	02623001	Sleeve hex 50mm	1
8	80900976	Bearing 32013	2
9	07037500	Spacer	2
10	02447500	Spacer	1
11	80900128	Bearing 30308	1
12	02622000	Input shaft	1
13	80900024	Bearing 30208	1
14	87100315	Oilseal 35x80x10	1
15	82500064	Ring nut M40x1.5	1
16	83800065	Spacer 40x62x1.5	1
17	02625000	Pinion gear 15T	1
18	02597525	Spacer	1
19	82500917	Ring nut M35x1.5	1
20	81200197	Socket head bolt M8x25	6
21	86700269	Plug	1
22	86500203	Plug	2
22	02621302	Rear cover	1

<u>No.</u>	<u>Part Number</u>	<u>Qty.</u>	<u>Description</u>
1	B41206	2	Cross and bearing kit
2	B204066851	1	Yoke-outer tube
3	B34104200	1	Roll pin
4	B125121500	1	Outer tube
5	B125091500	1	Inner tube
6	B341043000	1	Roll pin
7	B204066852	1	Yoke-inner tube
8	B5F07071F7	1	Complete PTO guard
10	B572060351	2	Yoke 540 RPM

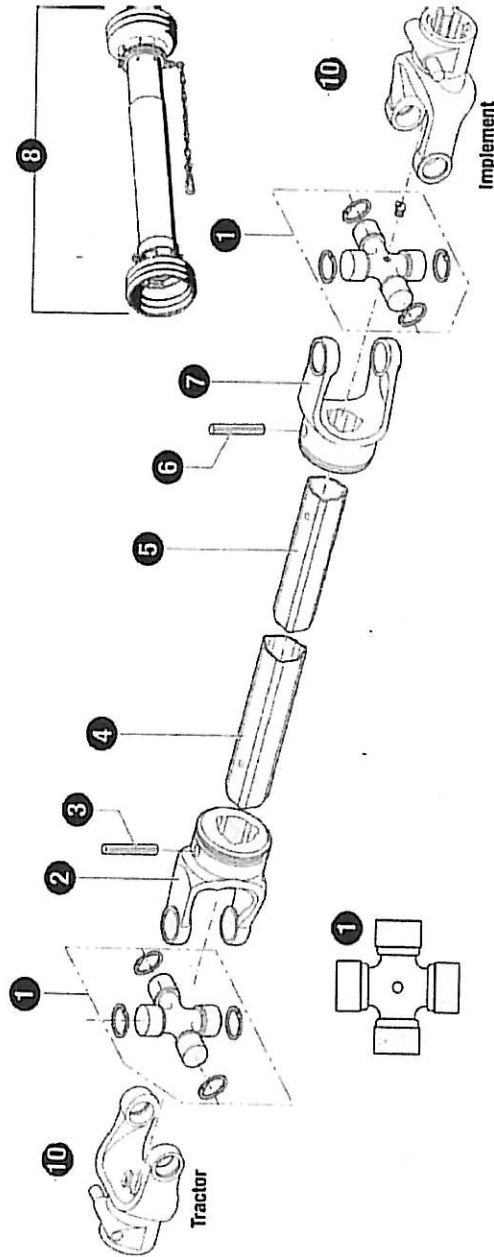

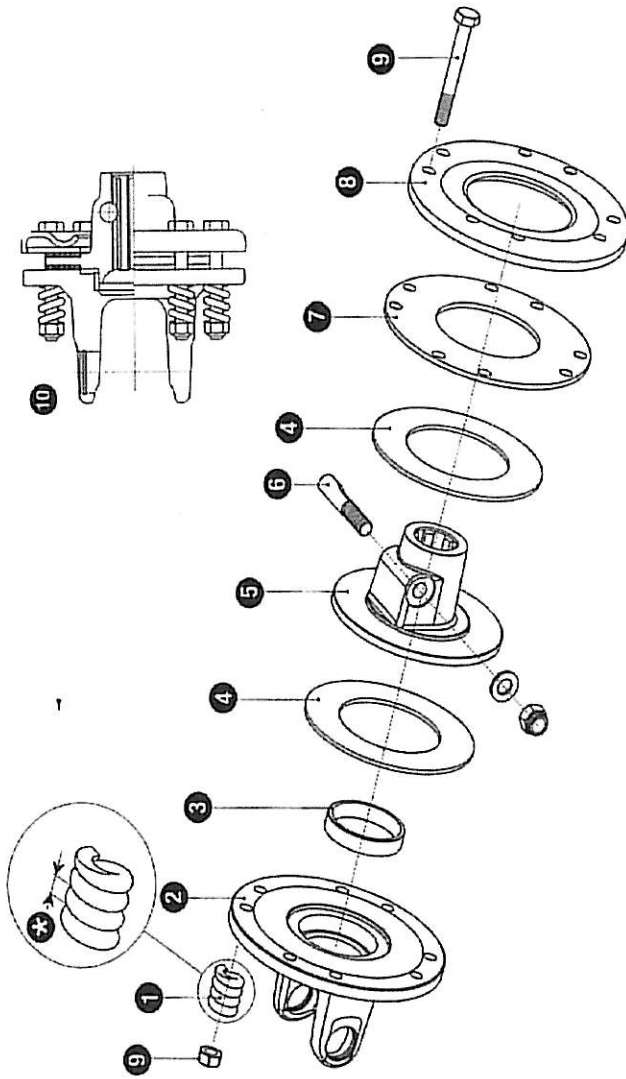

No.	Part Number	Qty.	Description
1	B351022370	8	Spring
2	B253062203	1	Flange yoke
3	B258005320	1	Bushing
4	B247000054	2	Friction disc
5	B515200311	1	Drive hub
6	B408000060	1	Pin kit
7	B248220008	1	Drive plate
8	B248220007	1	Thrust plate
9	B432000006	8	Bolt & nut
10	B639141001	1	Complete clutch assembly